

Energy band structures of strained membrane quantum wires considering the redistribution of elastic strain relaxation

Fahmida Ferdous¹

And

Anisul Haque²

¹Department of Electrical and Electronic Engineering,
Bangladesh University of Engineering and Technology,
Dhaka-1000, Bangladesh

²Department of Electrical and Electronic Engineering,
East West University, Dhaka-1212, Bangladesh

Outline

- Introduction
- Theory
- Numerical results
- Conclusions

Introduction (1)

Q-Wire lasers

- Low threshold current, • Higher gain, • Higher T_0

Dry-etching and OMVPE regrowth technique

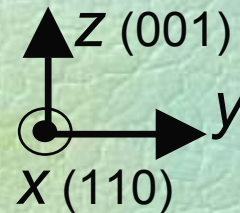
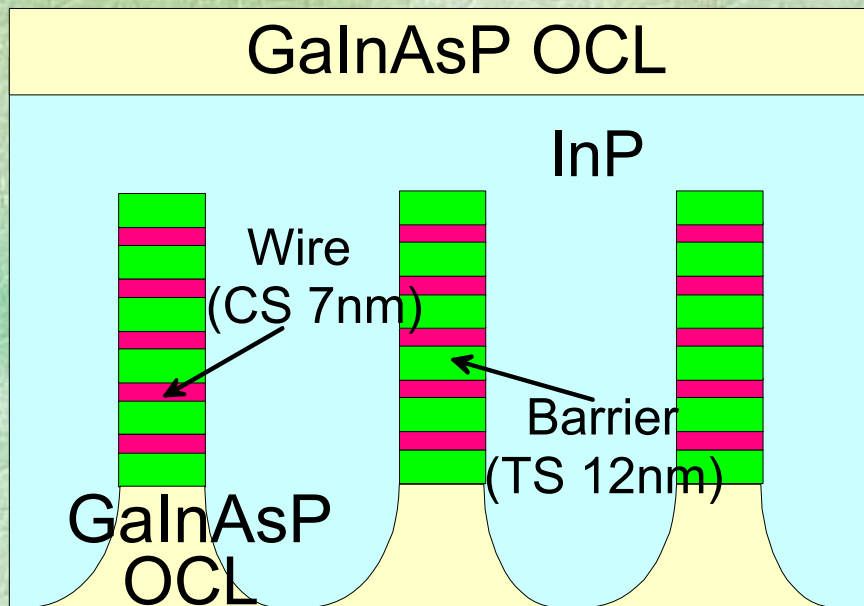

Advantages

- ★ Position controllability
- ★ Flexibility
- ★ Size distribution
- ★ Reliability

New structure: QWR membrane lasers

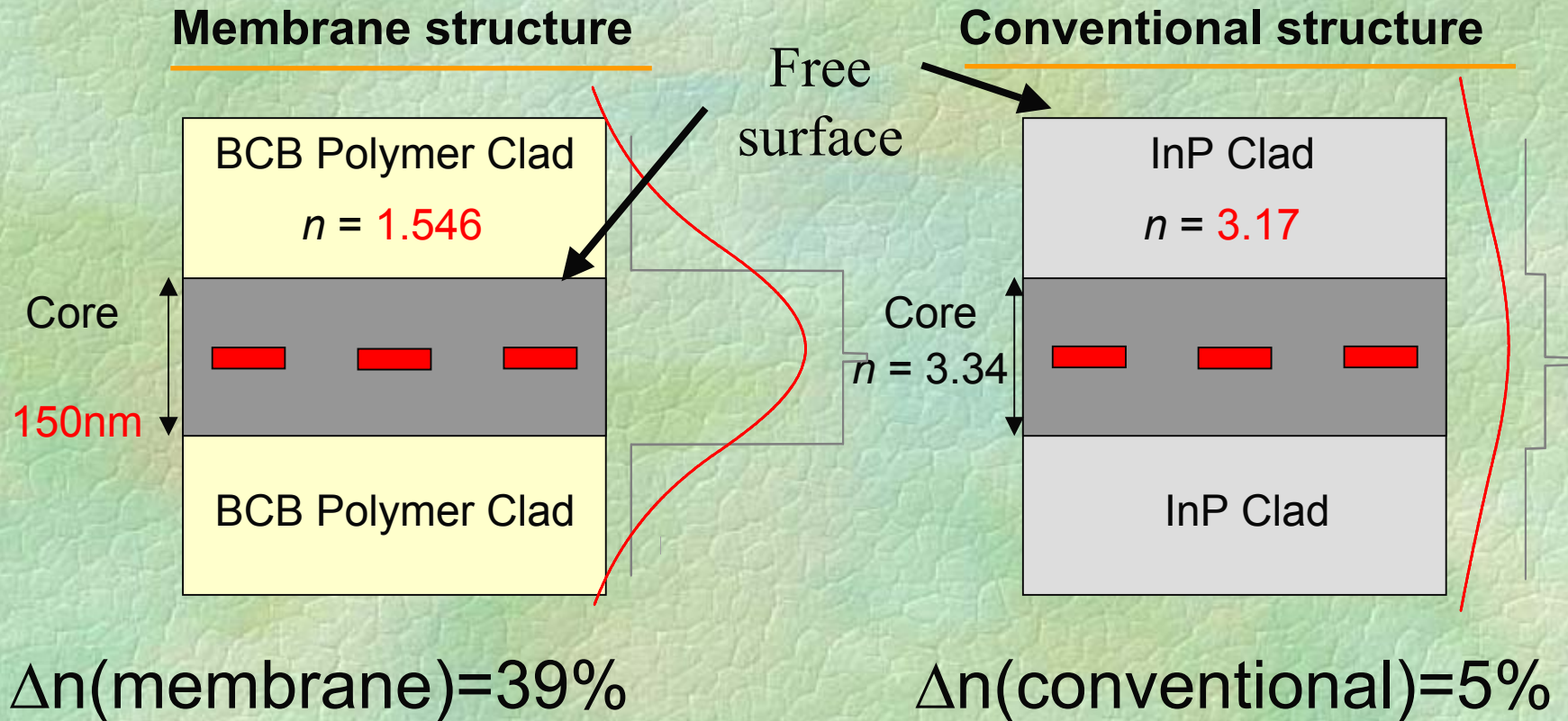

Introduction (3)

- ❖ In membrane structures, free surfaces are very close.
- ❖ Due to the closeness of free surfaces in membrane QWR, strain relaxation will be different. The strain relaxation is calculated including anisotropic and non-uniformity effects.
- ❖ Strain relaxation effects on electronic band structures in QWRs are investigated.

Theory (1)

Strain analysis

Equations of equilibrium

$$\left(C_{11} \frac{\partial^2}{\partial y^2} + \frac{1}{2} C_{44} \frac{\partial^2}{\partial z^2} \right) u + \left(C_{12} + \frac{1}{2} C_{44} \right) \frac{\partial^2 v}{\partial y \partial z} = 0$$

$$\left(C_{12} + \frac{1}{2} C_{44} \right) \frac{\partial^2 u}{\partial y \partial z} + \left(\frac{1}{2} C_{44} \frac{\partial^2}{\partial y^2} + C_{11} \frac{\partial^2}{\partial z^2} \right) v = 0$$

Plane strain



2D Deformation: (u, v)

$$\varepsilon_{yy} = \frac{\partial u}{\partial y} \quad \varepsilon_{zz} = \frac{\partial v}{\partial z} \quad \varepsilon_{yz} = \frac{1}{2} \left(\frac{\partial u}{\partial z} + \frac{\partial v}{\partial y} \right)$$

Solve by finite element method using FEMLAB software

Membrane

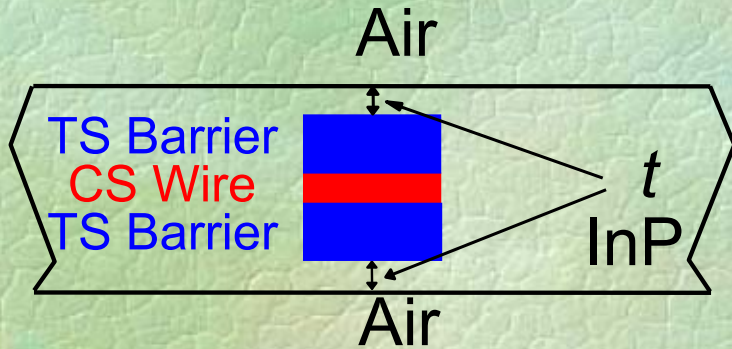

- $\sigma_{zz} = 0$ @ air-InP interface
- Complicated analysis
- Numerical solution

Conventional



Wire axis:
x

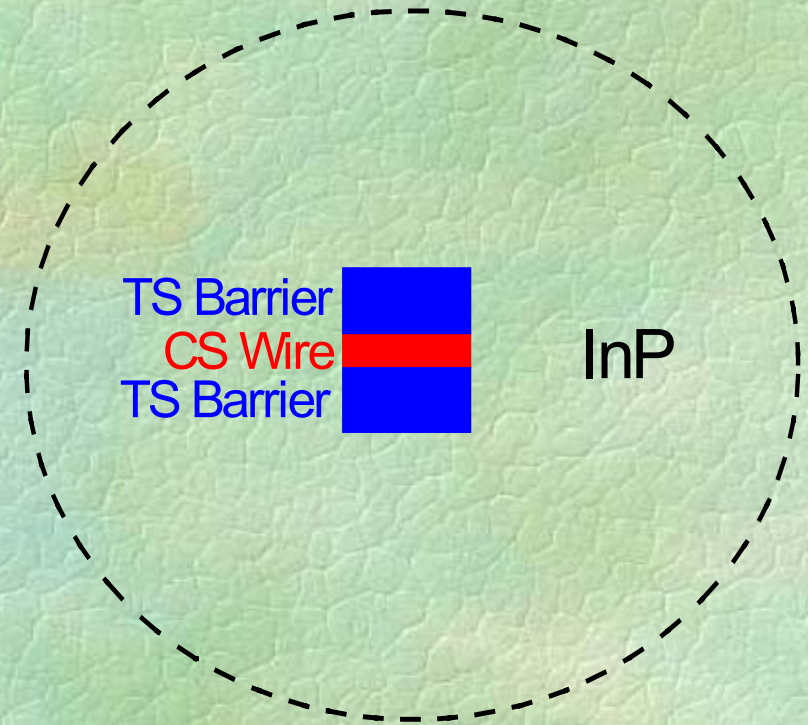

- Strain relaxes naturally
- Analytical solution exists

Theory (3)

Band structure calculation

8 band k.p method

$$H = \begin{bmatrix} G & \Gamma \\ -\Gamma^* & G^* \end{bmatrix}$$

$$G(k) = G_1(k) + G_2(k) + G_{so}(k) + G_{strain}(k)$$

$$\sum_{n'=1}^8 H_{nn'}(r, \nabla) F_{n'}(r) = E F_n(r)$$

Solve by eigenfunction expansion method

$$F_n(r) = \sum_{lm}^{\infty} F_n(l, m, k_x) \phi_{lmk_x}(x, y, z)$$

Theory (4)

❖ E_g is also calculated using deformation theory with bulk like CB and VB.

$$\text{❖ } E_g = E_{gu} + E_{gst}$$

$$\text{❖ } E_{gst} = a_c \varepsilon_{hy} - a_v \varepsilon_{hy} - b_v \varepsilon_{ax} / 2$$

$$\text{❖ } \Delta E_g = E_{gcon} - E_{gmem}$$

Theory (5)

- ❖ QWR is in 1.07% CS strain and 7 nm thick along growth direction.
- ❖ Barrier is 12 nm thick along growth direction.

Results (1)

0.15% TS barriers

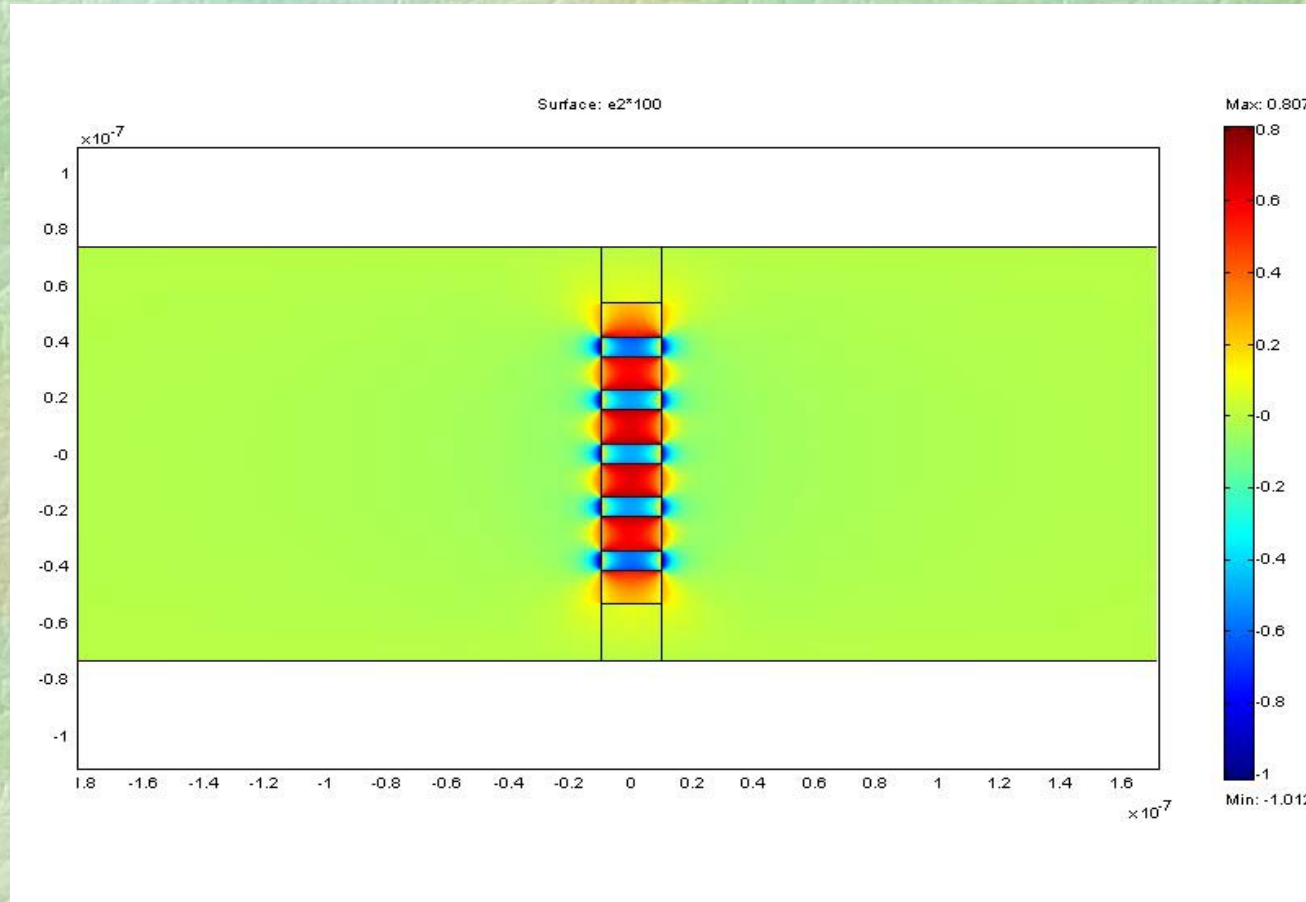

Surface plot ϵ_{yy} (membrane) (%)

Results (2)

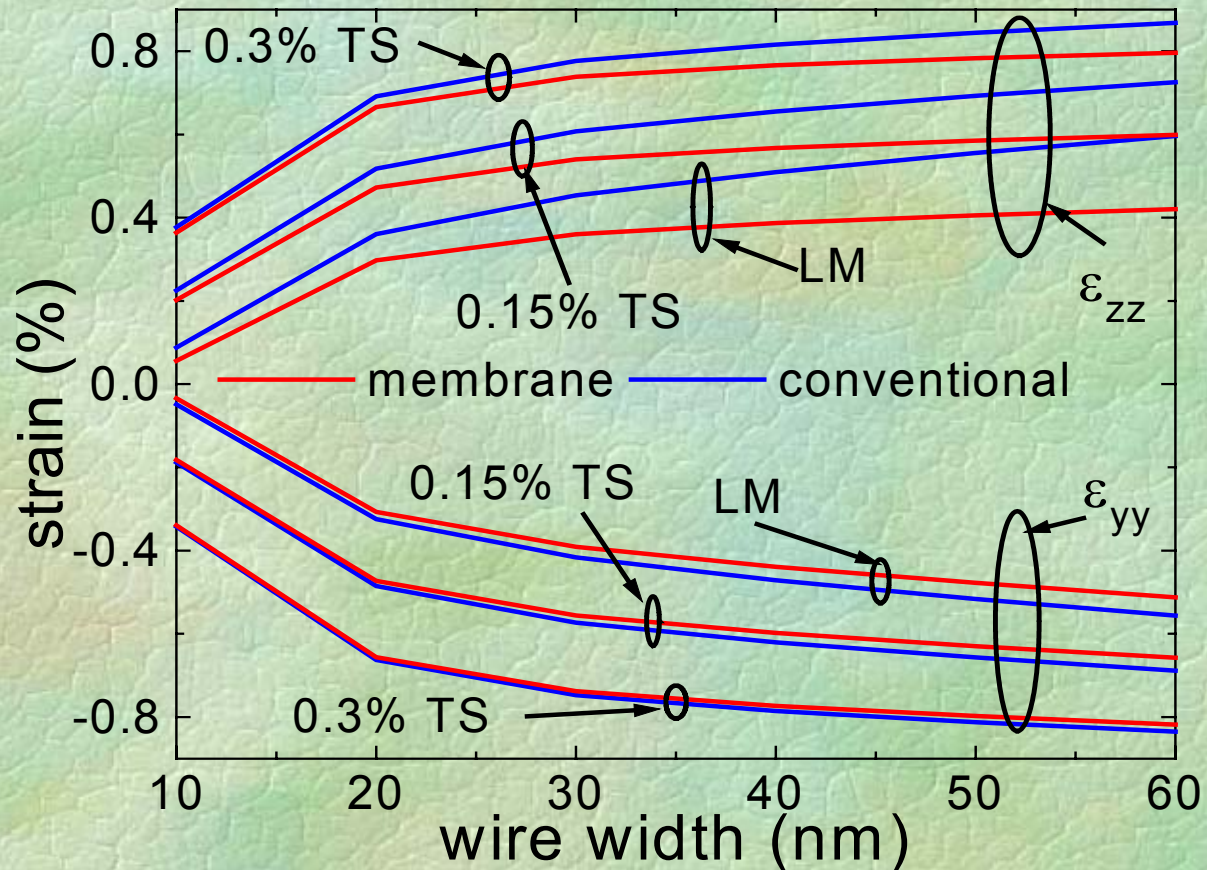

Pronounced on ϵ_{zz}

Depends on TS in Barriers

Results (3)

40 nm wire width

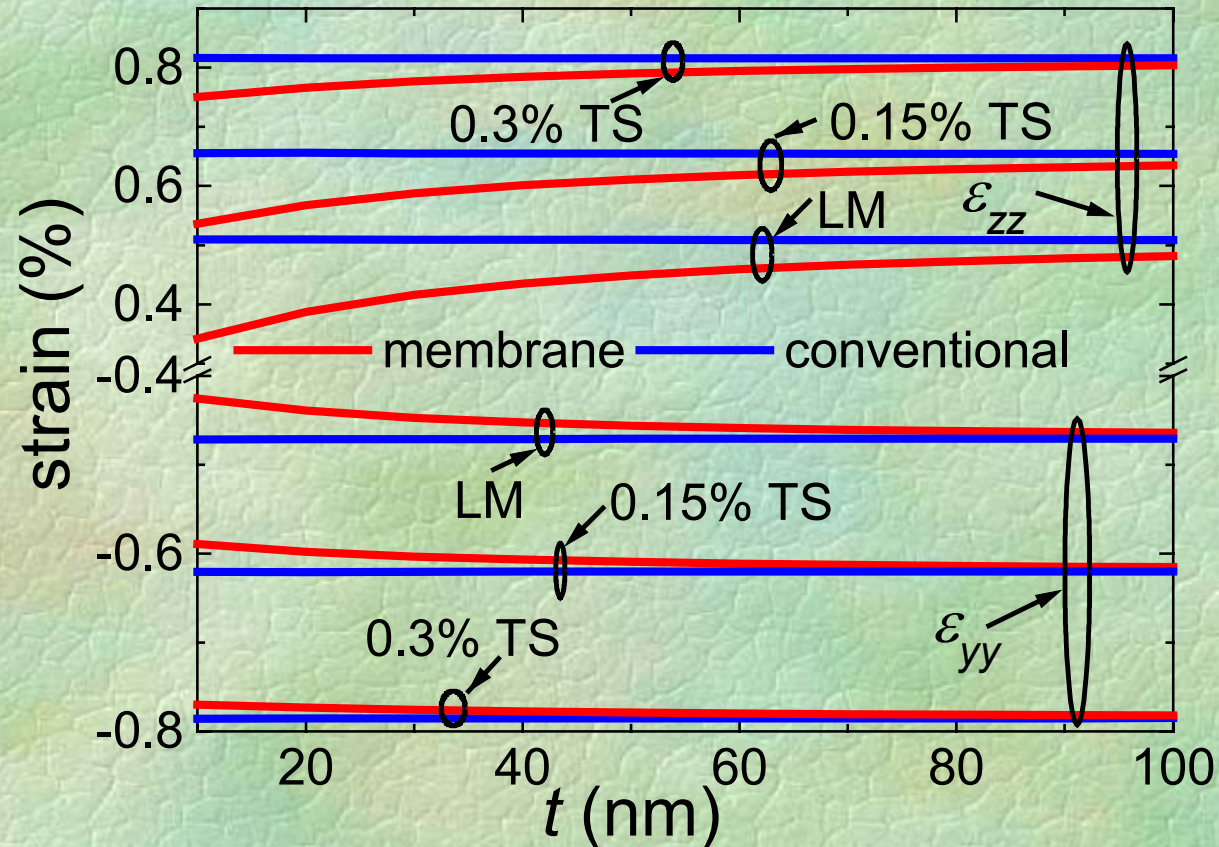

Depends on thickness of top and bottom InP layers (t)

Results (4)

0.15% TS

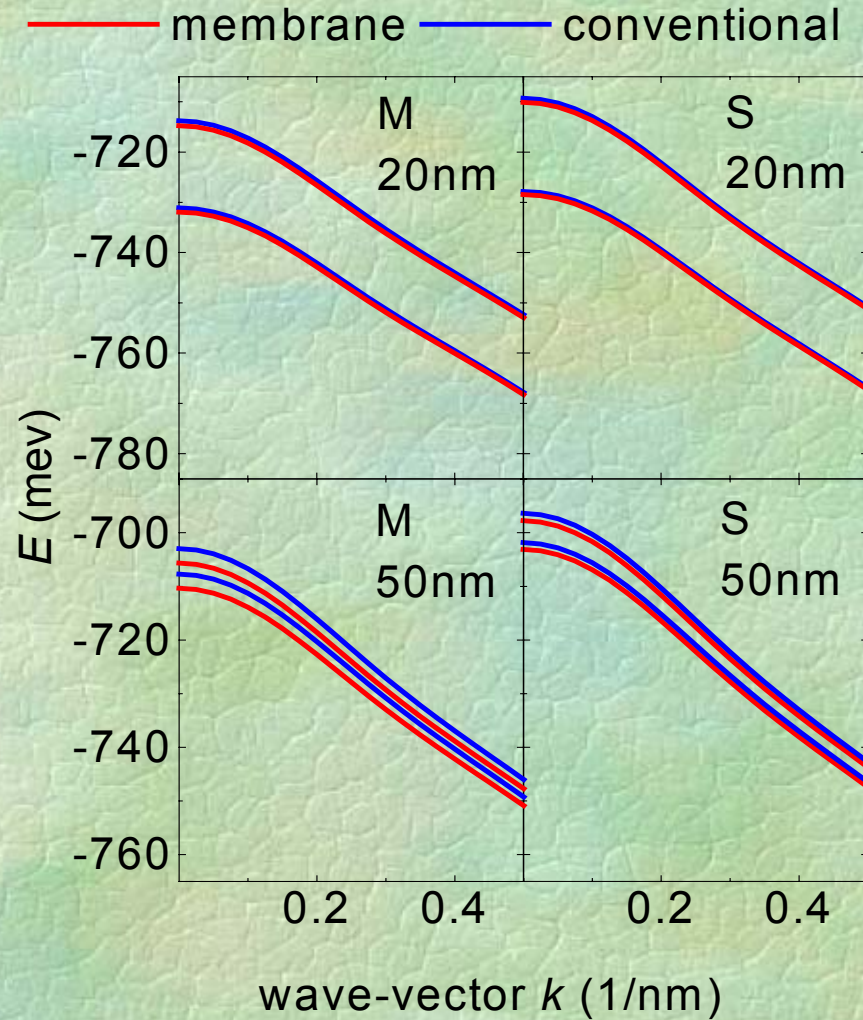

E_g in membrane structure increases : ΔE_g negative

Membrane: Blue shift

Results (5)

— membrane — conventional

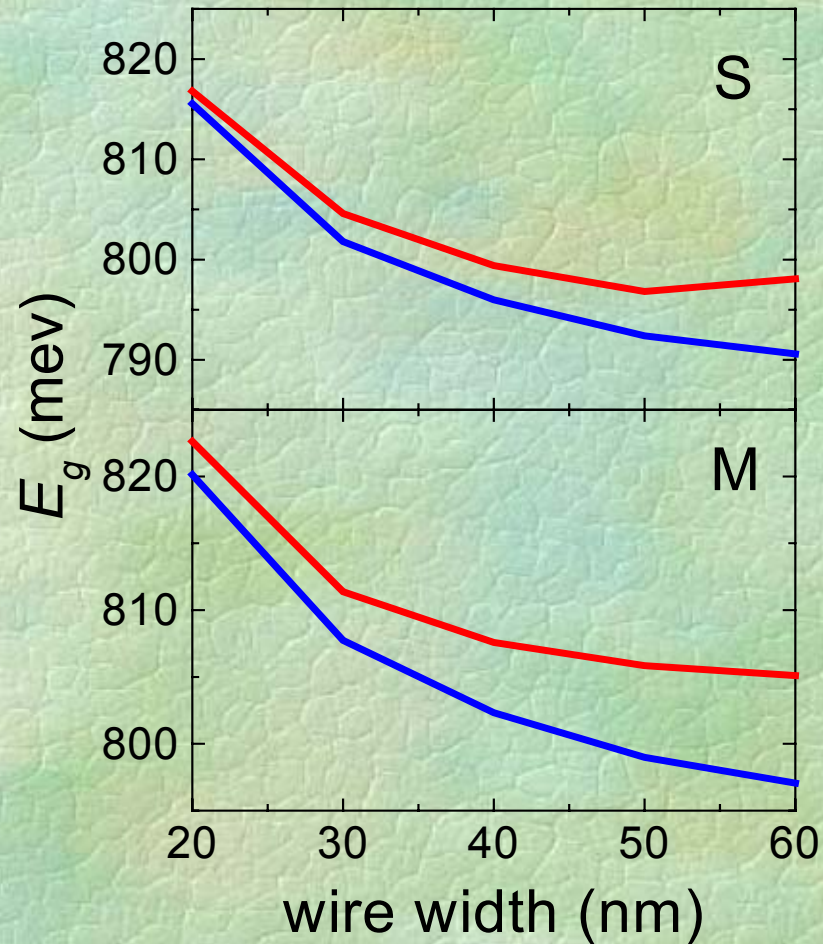

0.15% TS $t = 13$ nm

Results (6)

- with QM and band-mixing effects
- without QM and band-mixing effects

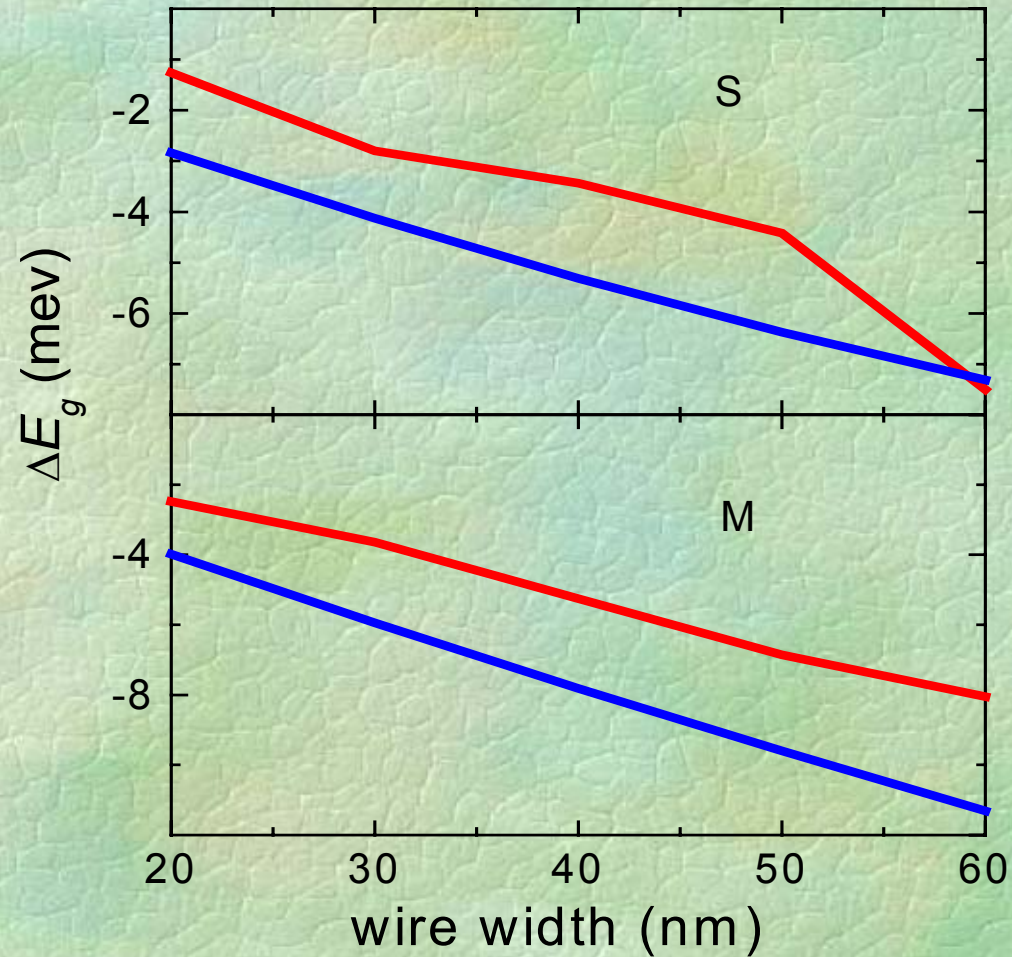

0.15% TS $t = 13$ nm

Results (7)

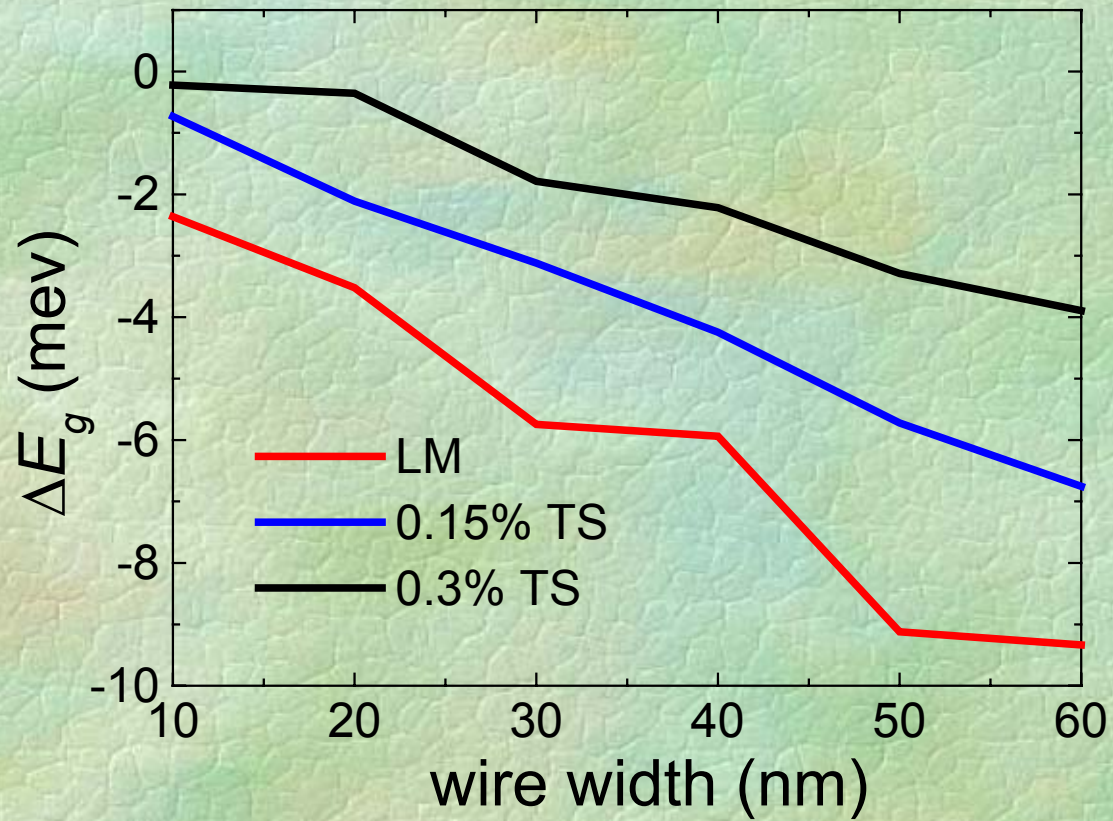

$t = 20$ nm

Results (8)

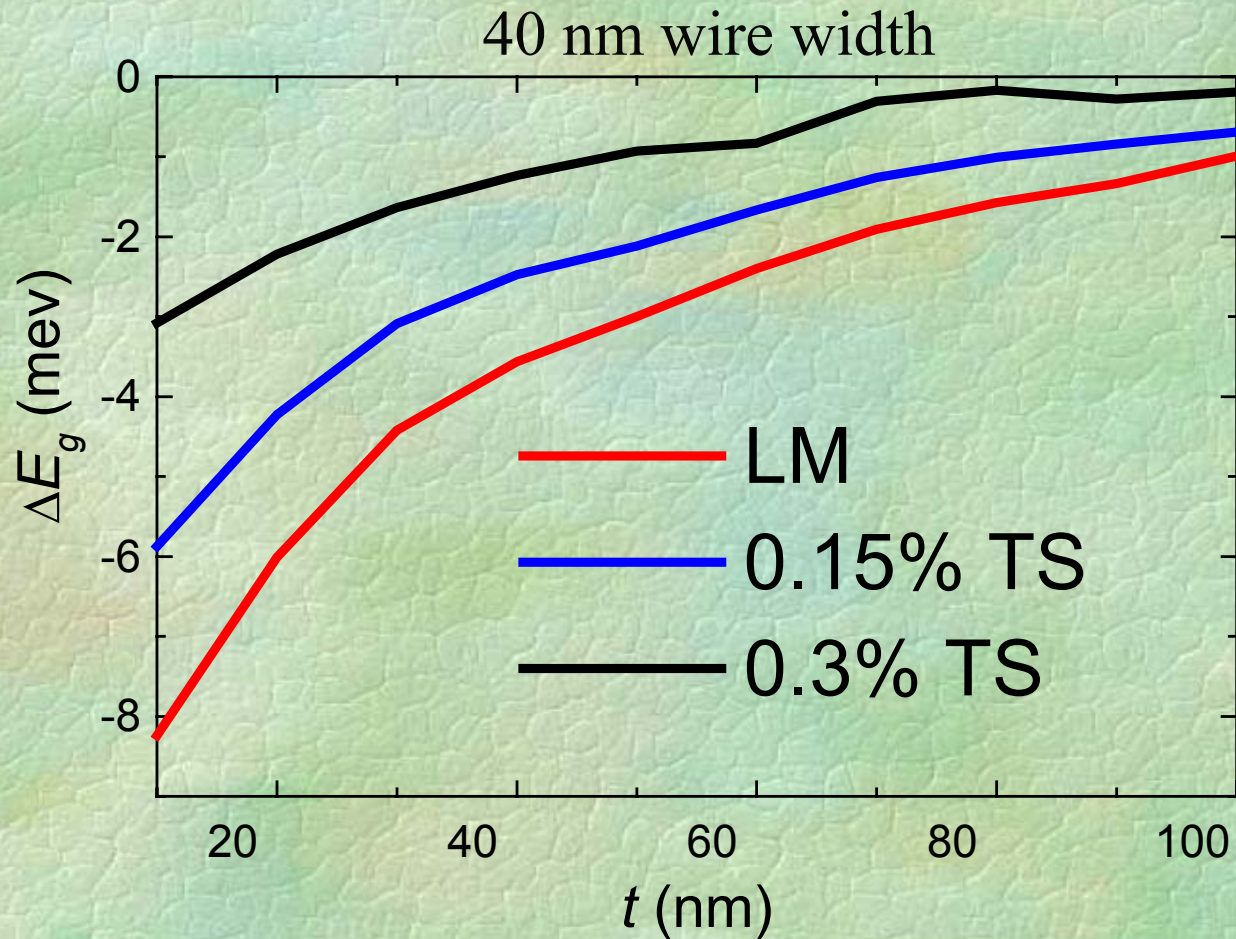

Conclusions

- Strain relaxation different in membrane QWR structures.
- Depends on *wire width, number of stacked layers, core thickness* etc.
- Strain relaxations strongly modify energy band structures.
- Blue shift due to etching.

Thank you.